

## FITTING INSTRUCTION

Clamp mark in acc. with		Cables joining
ISO	PN	
1	L	Left directional lights
2	+	Rear fog lights
3	31	Ground
4	R	Right directional lights
5	58R	Right side parking lights
6	54	Stoplights
7	58L	Left side parking lights

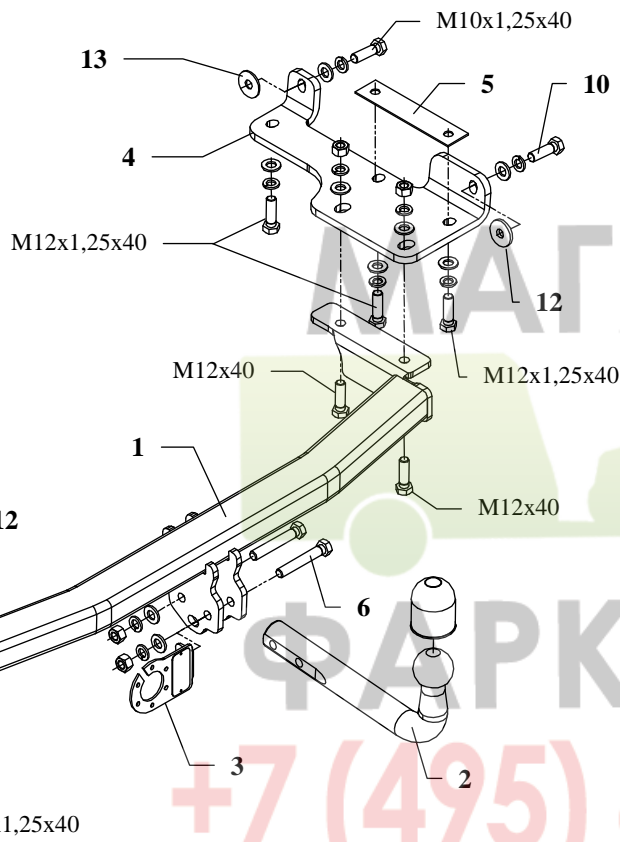

This towbar is designed to assembly in following cars: **NISSAN MURANO (Z50)**, produced since 11.2004 till 2008, catalogue no. **V62** and is prepared to tow trailers max total weight **1500kg** and max vertical load **100 kg**.

### From manufacturer

Thank you for buying our product. Their reliability has been confirmed in many tests. Reliability of towbar depends also on correct assembly and right operation. For this reasons we kindly ask to read carefully this instruction and apply to hints.

*The towbar should be install in points described by a car producer.*

## The instruction of the assembly

1. Disassemble a rear bumper.
2. In bottom part of the bumper cut out fragment (in axis) according to figure 2.
3. Disassemble bottom cover and cut out fragments according to figure 3.
4. To the right chassis member fix right bracket (pos. 4) by bolts M12x1,25x40mm (pos. 8) and M10x1,25x40mm (pos. 10)- loosely. Use big washers  $\varnothing 35 \times 12 \times 4$ mm (pos. 12) and  $\varnothing 35 \times 12 \times 2$  (pos. 13) and rectangular fish-plate (pos. 5), see figure 1.
5. To the left chassis member fix main bar of the towbar (pos. 1) by bolts M12x1,25x40mm (pos. 8) and M10x1,25x40mm (pos. 10). On the right side fix main bar to the already installed bracket (pos. 4) using bolts M12x40mm (pos. 9).
6. Fix tow-ball (pos. 2) with socket plate (pos. 3) using bolts M12x75mm (pos. 6) and M12x70mm (pos. 7) from accessories.
7. Tighten all bolts according to the torque shown in the table.
8. Connect electric wires of 7-poles socket according to the instruction of the car. (Recommend to make at authorized service station).
9. Complete paint layer damaged during installation.

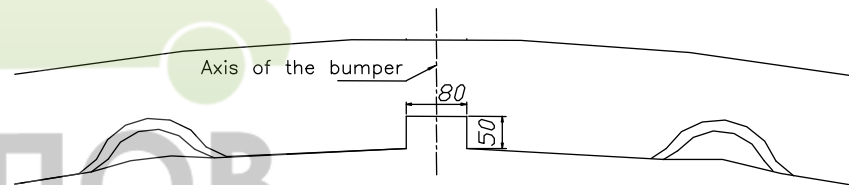

Fig. 2. Bumper cut out

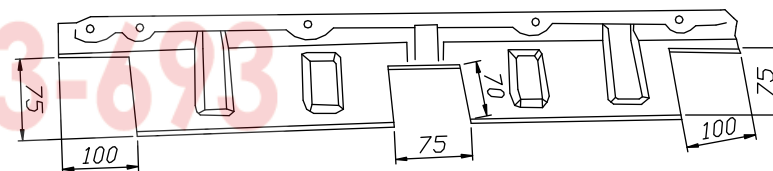

Fig. 3. Cover plate cut out

Torque settings for nuts and bolts (8,8):

M6 - 11 Nm	M8 - 25 Nm	M10 - 50 Nm
M12 - 87 Nm	M14 - 138 Nm	M16 - 210 Nm











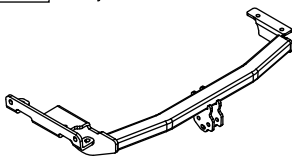
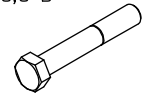

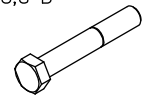

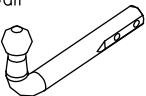
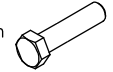
### NOTE

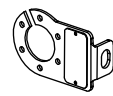
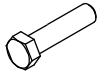
After install the towbar you should get adequate note in registration book (at authorised service station).The car should be equipped with:

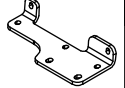
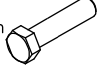
- Indicators
- Tow mirrors

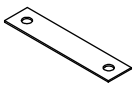
After **1000km** of exploitation check all bolts and nuts. The ball of towbar must be always kept clear and conserve with a grease.

Towbar accessories:

Pos. 1 Name: Main bar Quantity: 1 	Pos. 6 Name: Bolt 8,8 B Quantity: 1 Dim.: M12x75mm 	Pos. 12 Name: Washer Quantity: 2 Dim.: Ø35xØ12x4mm 
	Pos. 7 Name: Bolt 8,8 B Quantity: 1 Dim.: M12x70mm 	Pos. 13 Name: Washer Quantity: 2 Dim.: Ø35xØ12x2mm 
Pos. 2 Name: Tow ball Quantity: 1 	Pos. 8 Name: Bolt 8,8 B Quantity: 6 Dim.: M12x1,25x40mm 	Pos. 14 Name: Plain washer Quantity: 10 Dim.: Ø 13 mm 
Pos. 3 Name: Socket plate Quantity: 1 	Pos. 9 Name: Bolt 8,8 B Quantity: 2 Dim.: M12x40mm 	Pos. 15 Name: Spring washer Quantity: 10 Dim.: Ø 12,2 mm 
Pos. 4 Name: Right bracket Quantity: 1 	Pos. 10 Name: Bolt 8,8 B Quantity: 4 Dim.: M10x1,25x40mm 	Pos. 16 Name: Plain washer Quantity: 4 Dim.: Ø 10,5 mm 
Pos. 5 Name: Rectangular fish-plate Quantity: 1 	Pos. 11 Name: Nut 8 B Quantity: 4 Dim.: M12 	Pos. 17 Name: Spring washer Quantity: 4 Dim.: Ø 10,2 mm 
		Pos. 18 Name: Ball cover Quantity: 1 



**PPUH AUTO-HAK S.J.**

Produkcja Zaczepów Kulowych  
Henryk & Zbigniew Nejman  
76-200 SŁUPSK ul. Słoneczna 16K  
tel/fax (059) 8-414-414; 8-414-413  
E-mail: [office@autohak.com.pl](mailto:office@autohak.com.pl)  
[www.autohak.com.pl](http://www.autohak.com.pl)

**Towing hitch (without electrical set)**

Class: **A50-X** Cat. no. **V62**

Designed for:

Manufacturer: **NISSAN**

Model: **MURANO (Z50)**

produced since 11.2004 till 2008

Technical data:

**D-value: 9,1 kN**

maximum trailer weight: **1500 kg**

maximum vertical cup load: **100 kg**

**Approval number according to Directive 94/20/EC: e20\*94/20\*0093\*00**

**Foreword**

This towbar is designed according to rules of safety traffic regulations. The towing hitch is a safety component and can be install only by qualified personnel. Any alteration or conversion of the towing hitch is prohibited and would lead to cancellation of design certification. Remove insulating compound and underseal from vehicle (if present) in the area of the matting surfaces of the towing hitch. The vehicle manufacturer's specifications regarding trailer load and max. vertical cup load are decisive for driving whereat values for the towing hitch cannot be exceeded.

*D-value formula:*

$$\frac{\text{Max trailer weight [kg]} \times \text{Max vehicle weight [kg]}}{\text{Max trailer weight [kg]} + \text{Max vehicle weight [kg]}} \times \frac{9,81}{1000} = D \text{ [kN]}$$